

 **PIONEER**

Service Manual



DIRECT DRIVE TURNTABLE

PL-518

KCT, KUT, HGT

MODEL PL-518 COMES IN THREE VERSIONS DISTINGUISHED AS FOLLOWS:

Type	Voltage	Remarks
KCT	120V only	Canada model (without cartridge)
KUT	120V only	U.S.A. model (without cartridge)
HGT	220V and 240V	Europe or Oceania model (without cartridge)

CONTENTS

1.	SPECIFICATIONS	3
2.	PANEL FACILITIES AND OPERATION	4
3.	PART LOCATION	5
4.	MECHANISM OPERATION AND ADJUSTMENT	6
4.1	Start of Performance	6
4.2	Auto-Return Detection	6
4.3	Auto-Return Operation	7
4.4	Adjustment	7
5.	KCT, KUT TYPE EXPLODED VIEWS	
5.1	Cabinet	9
5.2	Tonearm	10
5.3	Mechanism	11
5.4	Packing	12
6.	NOMENCLATURE OF SCREWS, WASHERS AND NUTS	13
7.	KCT TYPE SCHEMATIC DIAGRAM, P.C. BOARD PATTERN AND PARTS LIST	
7.1	Power Supply Assembly (PWR-032)	14
7.2	Schematic Diagrams	15
8.	KUT TYPE SCHEMATIC DIAGRAM, P.C. BOARD PATTERN AND PARTS LIST	
8.1	Schematic Diagram	17
8.2	Power Supply Assembly (PWR-037)	19
9.	HGT TYPE EXPLODED VIEWS	
9.1	Cabinet	20
9.2	Tonearm	21
9.3	Mechanism	22
9.4	Packing	23
10.	HGT TYPE SCHEMATIC DIAGRAM, P.C. BOARD PATTERNS AND PARTS LIST	
10.1	Power Supply Assembly A (PWR-035)	24
10.2	Power Supply Assembly B (PWR-028)	24
10.3	Schematic Diagram	25

1. SPECIFICATIONS

Motor and Turntable

Drive System:	Direct-drive
Motor:	DC servomotor (16 pole 24 slot)
Turntable Platter:	320mm diam. aluminum alloy die-cast
Speeds:	33-1/3 and 45rpm
Speed Control Range:	±2%
Wow and Flutter:	Less than 0.03% (WRMS)
Signal-to-Noise Ratio:	More than 73dB (DIN-B) (with Pioneer cartridge model PC-135)

Tonearm

Type:	Static-balance type, S-shaped pipe arm
Effective Arm Length:	221mm
Overhang:	15.5mm
Tracking Error:	0.525 deg./in, 0.21 deg./cm
Usable Cartridge Weight:	4g (min.) to 10g (max.)

Other Features

Auto-return mechanism, Anti-skating force control, Cueing device
Detachable dust cover, Insulator feet, Plug-in type headshell
Strobe light, 40mm-thick particle board cabinet

Miscellaneous

Power Requirements:	AC 120V, 50/60Hz (KCT, KUT)
Power Requirements:	AC 220-240V ~, 50/60Hz (HGT)
Power Consumption:	7W
Dimensions:	440(W) x 145(H) x 365(D) mm 17-5/16(W) x 5-11/16(H) x 14-3/8(D) in
Weight:	9.5kg/20lb 15oz

Accessories

EP adaptor	1
Screwdriver	1
Cartridge mounting screws	6
Cartridge mounting nuts	2
Cartridge mounting washers	2
Operating instructions (KCT, KUT)	1
Operating instructions (HGT)	2

NOTE:

Specifications and design subject to possible modification without notice, due to improvements.

HGT only

For Use in United Kingdom and Australia

Please note:

Models employ 3-conductor mains leads. Please read the following instructions carefully before connecting.

WARNING: THIS APPARATUS MUST BE EARTHED.

CAUTION 240V: MAINS SUPPLY VOLTAGE IS FACTORY ADJUSTED AT 240 VOLTS.

IMPORTANT

The wires in this mains lead are coloured in accordance with following code:

Green-and-yellow:	Earth
Blue:	Neutral
Brown:	Live

As the colours of the wires in the mains lead of this apparatus may not correspond with the coloured markings identifying the terminals in your plug, proceed as follows.

The wire which is coloured green-and-yellow must be connected to the terminal in the plug which is marked by the letter E or by the safety earth symbol \oplus or coloured green or green-and-yellow.

The wire which is coloured blue must be connected to the terminal which is marked with the letter N or coloured blue or black.

The wire which is coloured brown must be connected to the terminal which is marked with the letter L or coloured brown or red.

The power cord should be connected last, make sure that the Power switch is OFF.

First insert the female appliance connector of the mains cord into the AC inlet, then plug the cord to the wall socket.

Be sure the appliance connector is fully inserted into the AC inlet.

Unplug the set from the wall socket when it is not to be used for an extended period of time.

FOR YOUR SAFETY

1. Insert this plug only into effectively earthed three-pin plug-socket outlet.
2. If any doubt exists regarding the earthing, consult a qualified electrician.
3. Extension cords, if used, must be three-core correctly wired.

2. PANEL FACILITIES AND OPERATION

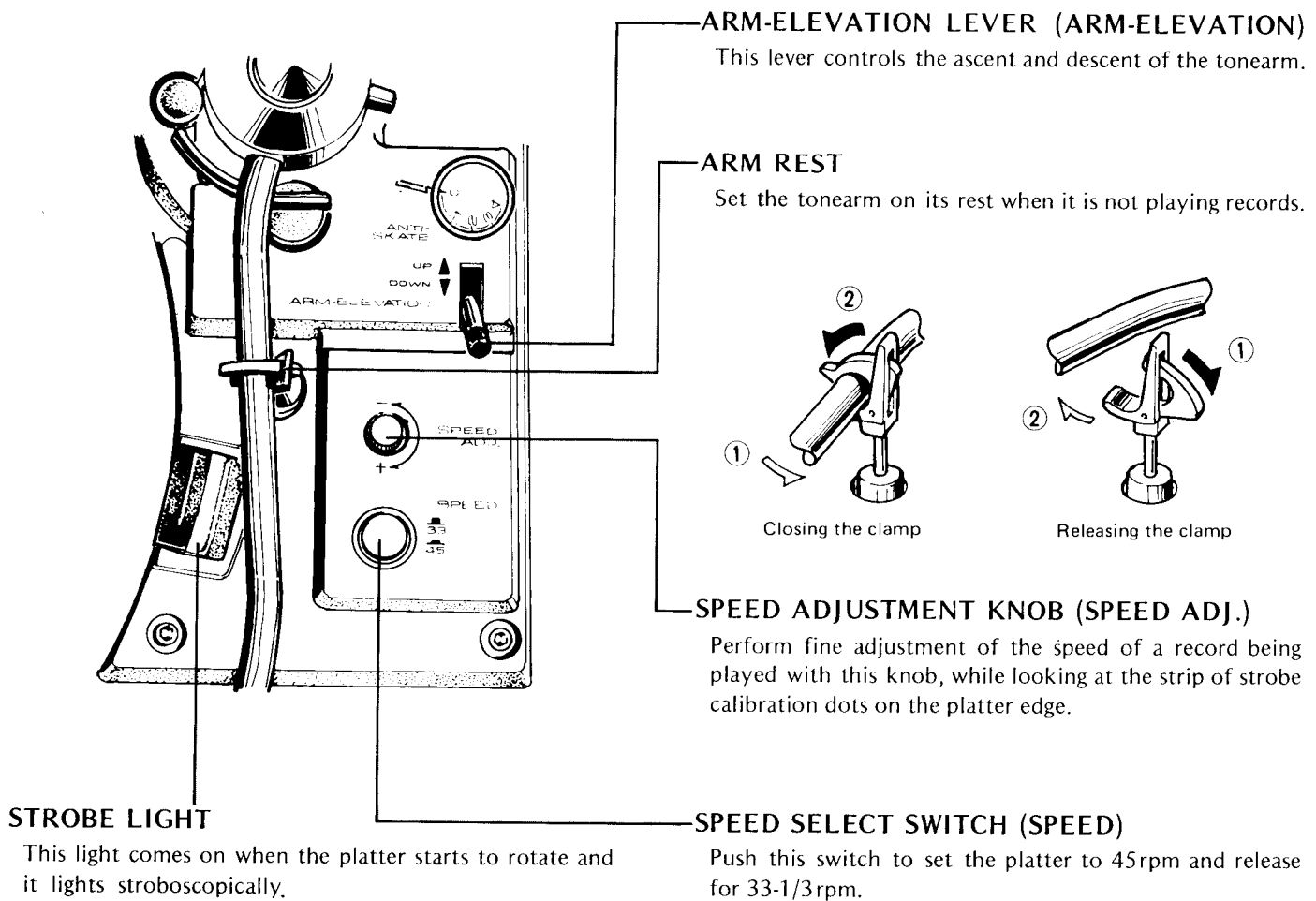

OPERATION

1. Place the record to be played on the platter.
2. Set the SPEED select switch to the speed at which the record is to be played.
3. Set the ARM-ELEVATION lever to the UP ▲ position.
4. Remove the stylus cover and release the arm clamp.
5. Hold the headshell by the finger lift and move the stylus across the record to the track you want played. The platter will begin to rotate.
6. Observe the appropriate strip of strobe calibration dots on the platter edge. If the strobe dot is not stationary, finely adjust the platter speed with the SPEED ADJ. knob according to "HOW TO FINELY ADJUST THE PLATTER SPEED" on page 7.
7. Set the ARM-ELEVATION lever to the DOWN ▼ position.
The stylus will descend slowly to the record and play will begin.
8. Adjust the volume and tone controls on the amplifier to the preferred levels, and then sit back and enjoy your record.
9. After the record has been played, the auto-return mechanism is actuated and the tonearm returns to the arm rest. At the same time, the platter stops rotating and the power to the turntable is turned off.
10. Secure the tonearm to the arm rest with the clamp and attach the stylus cover to protect the stylus.

3. PART LOCATION

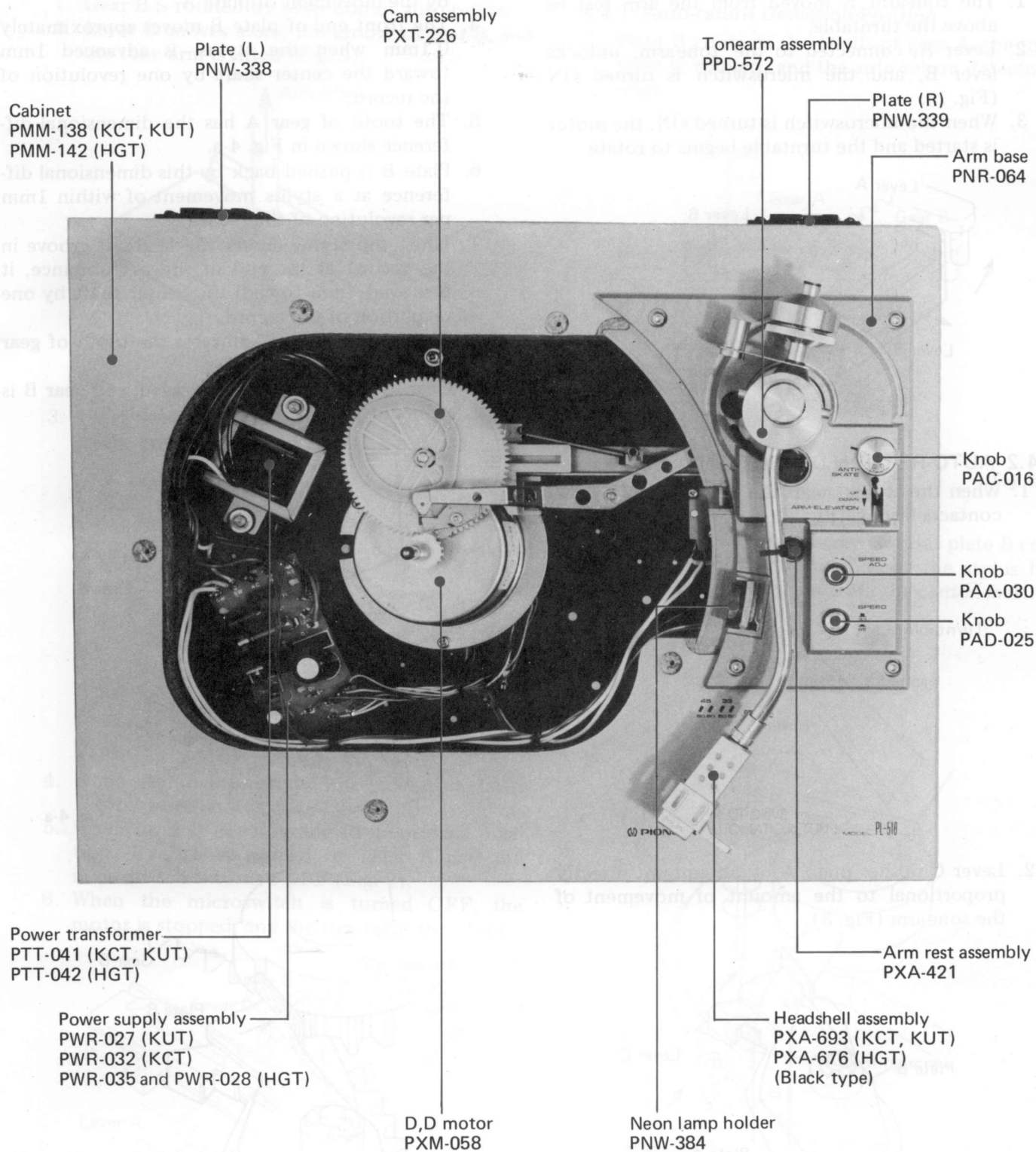

4. MECHANISM OPERATION AND ADJUSTMENT

4.1 START OF PERFORMANCE

1. The tonearm is moved from the arm rest to above the turntable.
2. Lever A, connected to the tonearm, unlocks lever B, and the microswitch is turned ON (Fig. 1).
3. When the microswitch is turned ON, the motor is started and the turntable begins to rotate.

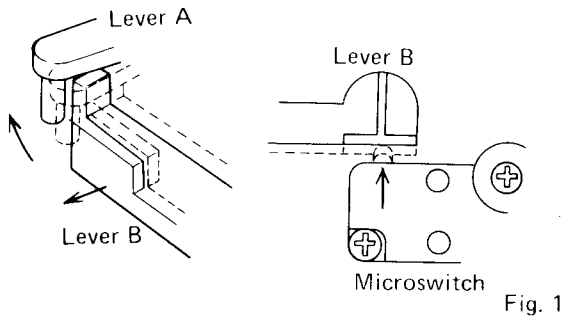

Fig. 1

4.2 AUTO-RETURN DETECTION

1. When the stylus nears the center shaft, lever A contacts lever C (Fig. 2).

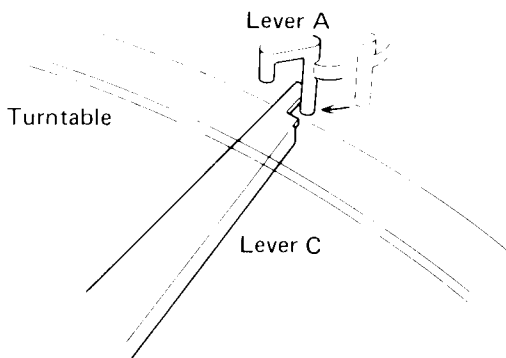

Fig. 2

2. Lever C pushes plate A by an amount directly proportional to the amount of movement of the tonearm (Fig. 3).

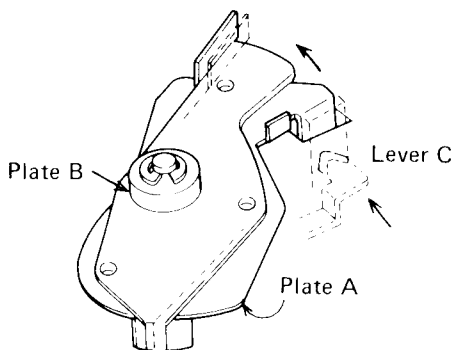

Fig. 3

3. Plate B atop plate A is moved toward gear A by the movement of plate A.
4. The front end of plate B moves approximately 0.1mm when the stylus is advanced 1mm toward the center shaft by one revolution of the record.
5. The tooth of gear A has the dimensional difference shown in Fig. 4-a.
6. Plate B is pushed back by this dimensional difference at a stylus movement of within 1mm per revolution of the record.
7. When the stylus enters the lead-out groove in the record at the end of the performance, it is moved 4mm toward the center shaft by one revolution of the record.
8. The end of plate B contacts the tooth of gear A (Fig. 4-b).
9. Gear A and gear B are engaged, and gear B is turned by rotation of the turntable.

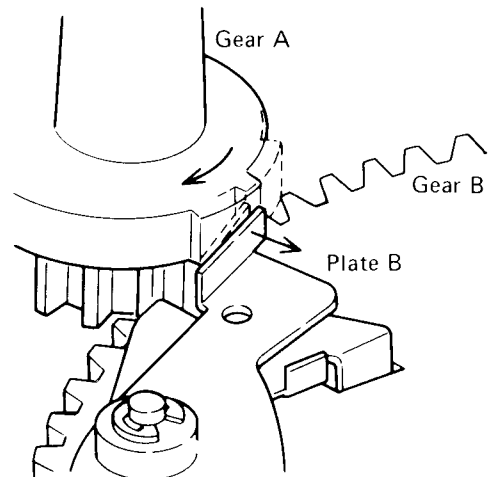

Fig. 4-a

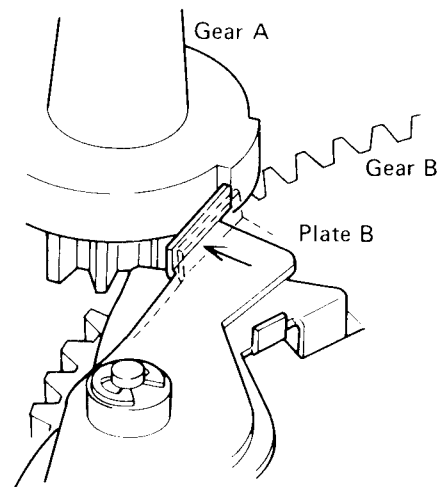

Fig. 4-b

4.3 AUTO-RETURN OPERATION

1. Gear B is rotated by detection of auto-return.
2. Lever D moves along the groove of gear B, and the tone arm is lifted (Fig. 5).

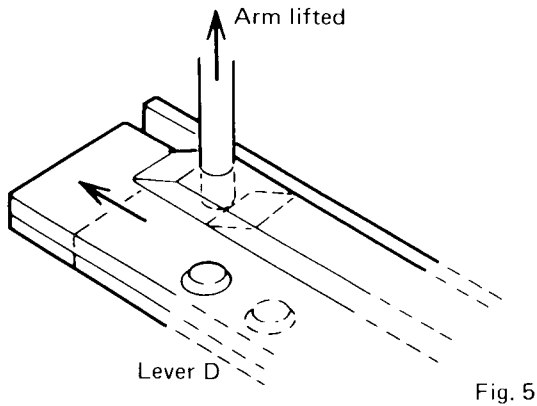

Fig. 5

3. Lever A is pushed and the tonearm is returned to the arm rest by lever D (Fig. 6).

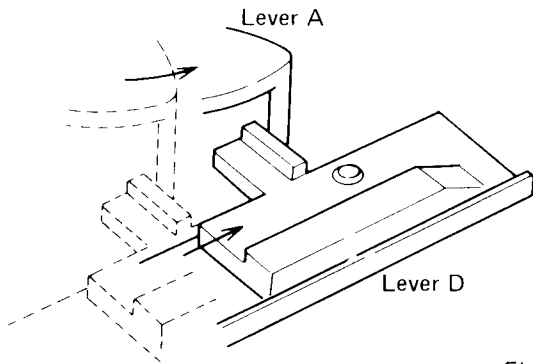

Fig. 6

4. When gear B has rotated one revolution, lever D is returned to its original position.
5. When lever D has returned to its original position, lever B is pushed by lever A and the microswitch is turned OFF (Fig. 7).
6. When the microswitch is turned OFF, the motor is stopped, and the turntable also stops.

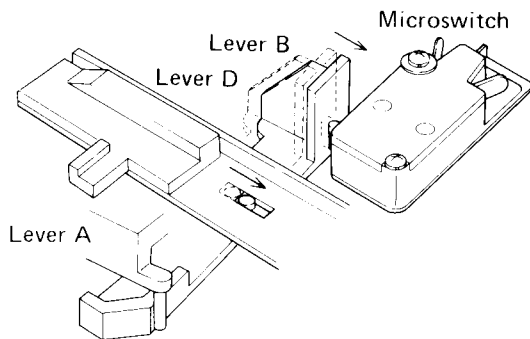

Fig. 7

4.4 ADJUSTMENT

4.4.1 Auto-return Detection Position

1. Plate B contacts the tooth of gear A, the turntable is rotated, and the auto-return detector is reset.

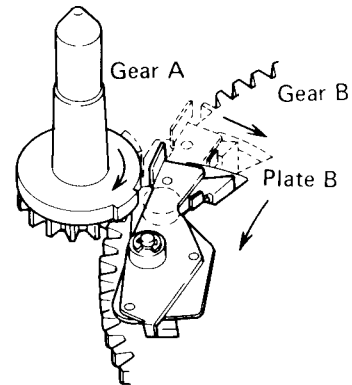

Fig. 8

2. Adjust the adjusting screw so that plate B contacts the tooth of gear A when the stylus has reached a point 62mm from the center shaft.

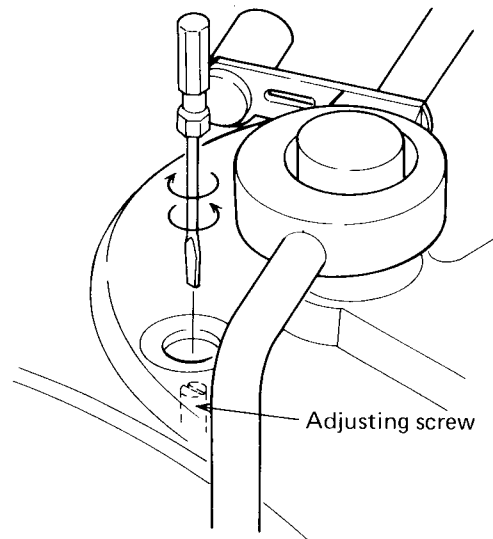
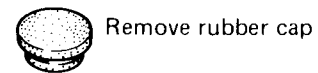

Fig. 9

4.4.2 Microswitch ON Timing

1. Adjust at the adjusting point shown in Fig. 10-b so that lever A and lever B become as shown in Fig. 10-a when the tonearm is fastened to the arm rest.
2. Adjust the adjusting screw (Fig. 10-c) so that lever B and the microswitch are positioned as shown in Fig. 10-c when the tonearm is fastened to the arm rest.
3. Since this adjustment will adversely effect the auto-return detection position, the auto-return detection position must be readjusted.

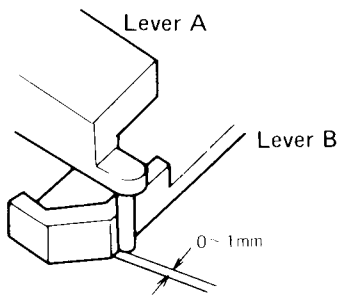

Fig. 10-a

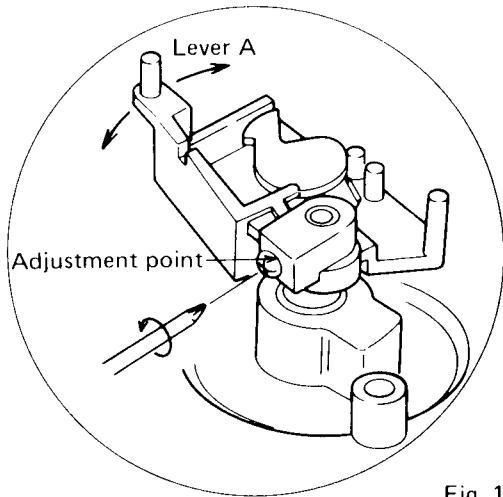

Fig. 10-b

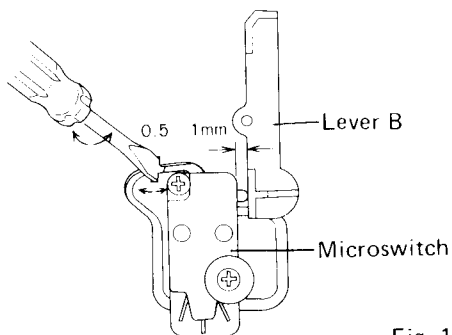

Fig. 10-c

4.4.3 Speed Adjustment

1. Set the SPEED ADJ knob on the control panel to its mechanical center when adjusting the speed.
2. Adjust the speed with the semi-fixed resistor on the motor control board (Fig. 11).

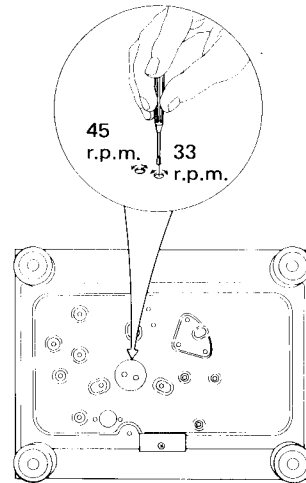

Fig. 11

5. KCT, KUT type EXPLODED VIEWS

5.1 CABINET

NOTE:

Parts indicated in mark cannot be supplied.

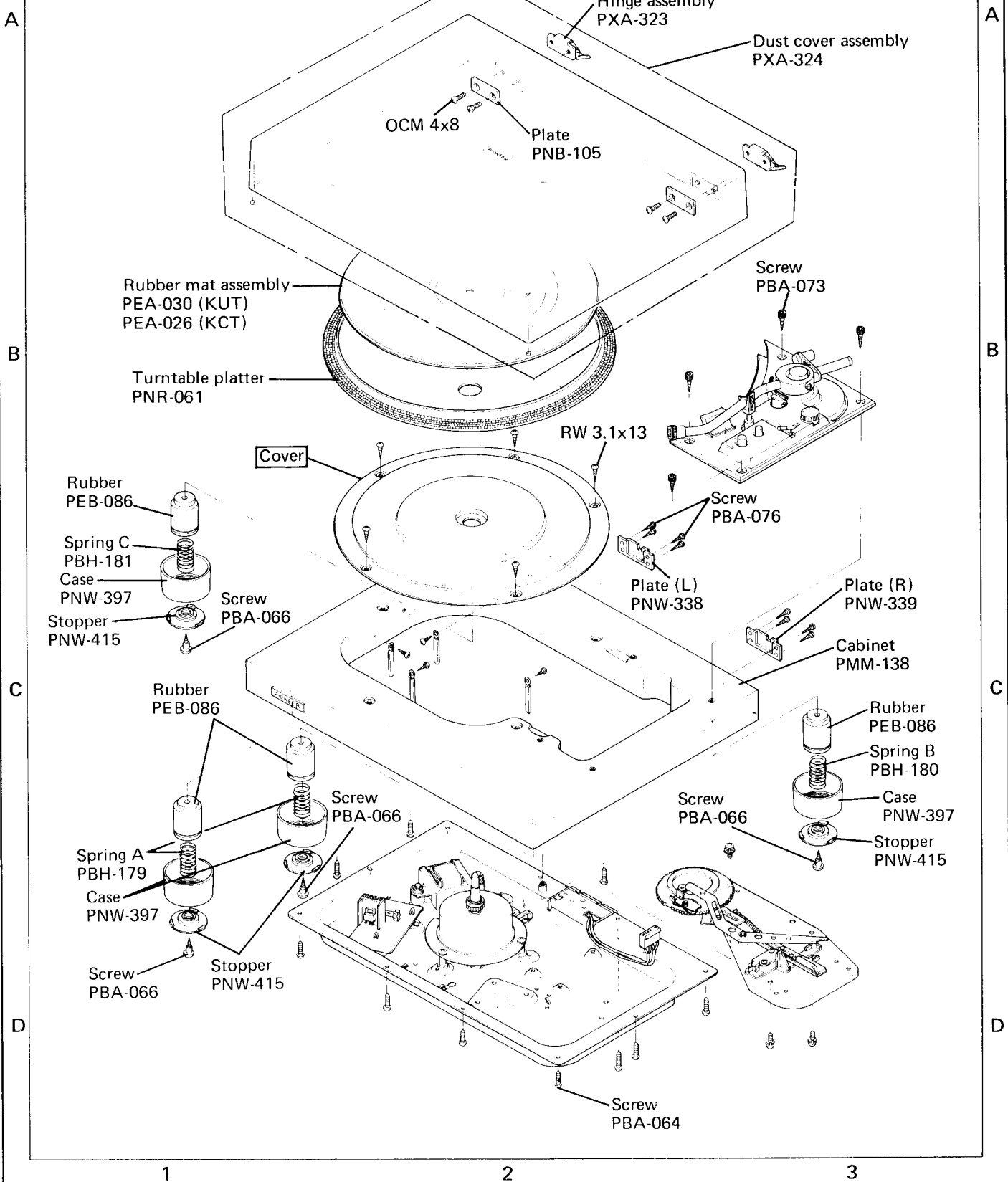

5.3 MECHANISM

NOTE:

Parts indicated in mark cannot be supplied.

A

A

B

B

C

C

D

D

1

2

3

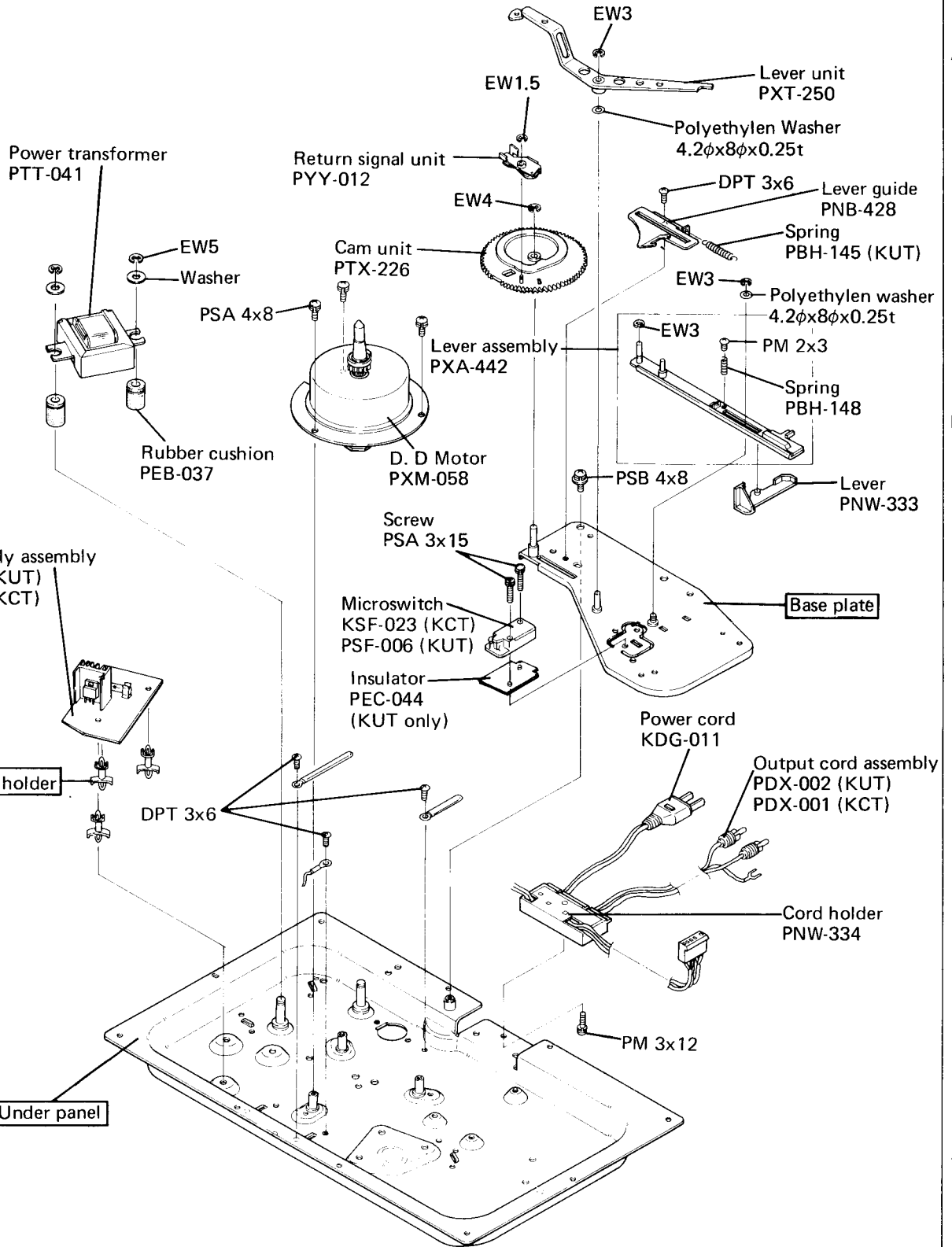

1

2





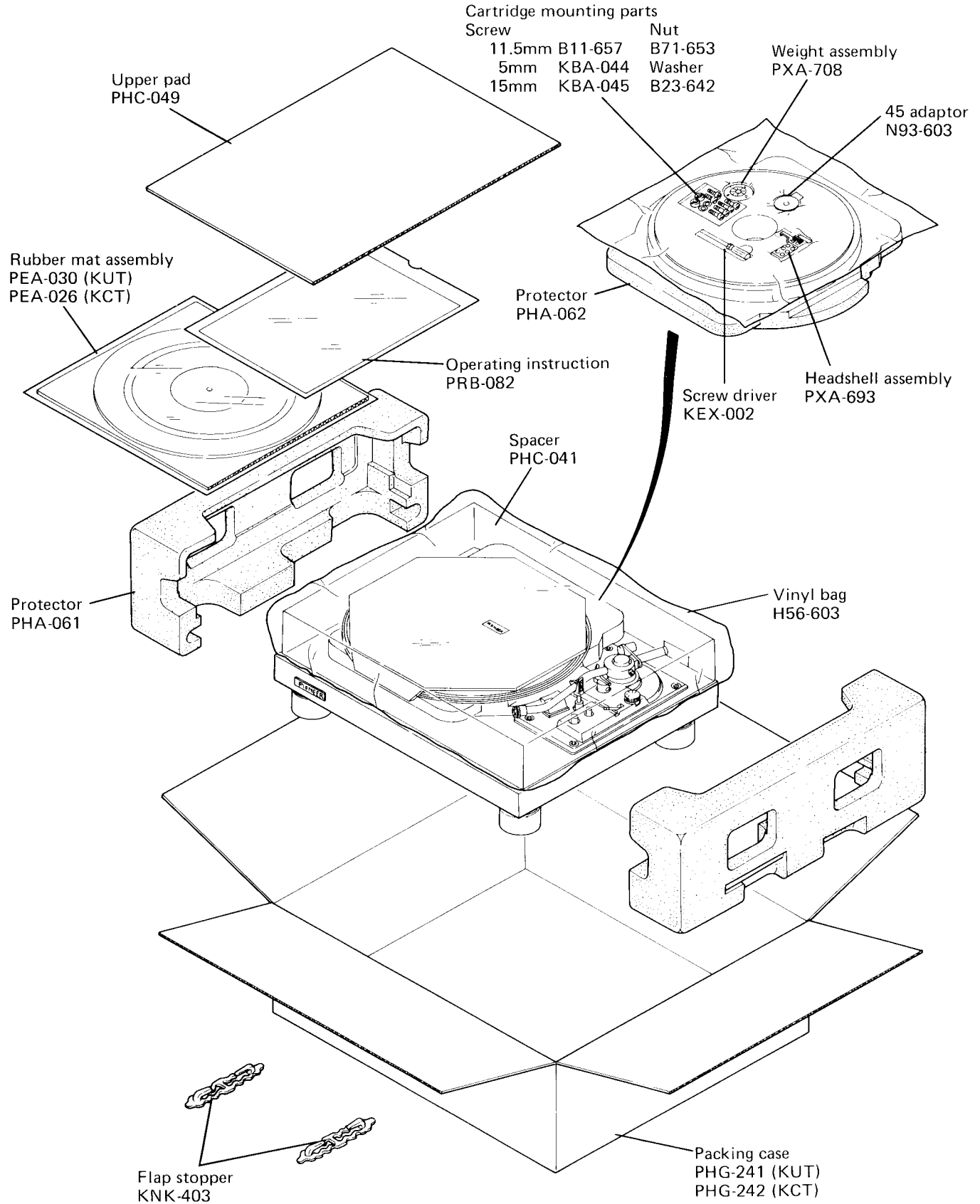









3













5.4 PACKING

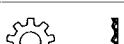

6. NOMENCLATURE OF SCREWS, WASHERS AND NUTS

The following symbols stand for screws, washers and nuts as shown in exploded view.

Symbol	Description	Shape
RT	Brazier head tapping screw	
PT	Pan head tapping screw	
BT	Binding head tapping screw	
DPT	Delta tight pan head tapping screw	
APT	Aluminum pan head tapping screw	
OCT	Oval countersunk head tapping screw	
PM	Pan head machine screw	
CM	Countersunk head machine screw	
OCM	Oval countersunk head machine screw	
TM	Truss head machine screw	
BM	Binding head machine screw	
PSA	Pan head screw with spring lock washer	
PSB	Pan head screw with spring lock washer and flat washer	
PSF	Pan head screw with flat washer	

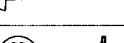
Symbol	Description	Shape
EW	E type washer	
FW	Flat washer	
SW	Spring lock washer	
N	Nut	
WN	Washer faced nut	
ITW	Internal toothed lock washer	
OTW	Outernal toothed lock washer	
SC	Slotted set screw (Cone point)	
SF	Slotted set screw (Flat point)	
HS	Hexagon socket headless set screw	
OCW	Oval countersunk head wood screw	
CW	Countersunk head wood screw	
RW	Round head wood screw	
CS-TW	Stopper washer	

EXAMPLE

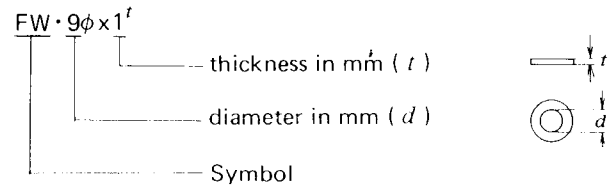
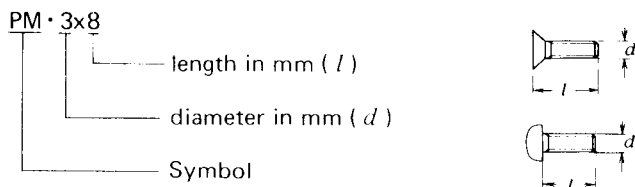

7. KCT type SCHEMATIC DIAGRAM, P.C. BOARD PATTERN AND PARTS LIST.

7.1 POWER SUPPLY ASSEMBLY (PWR-032)

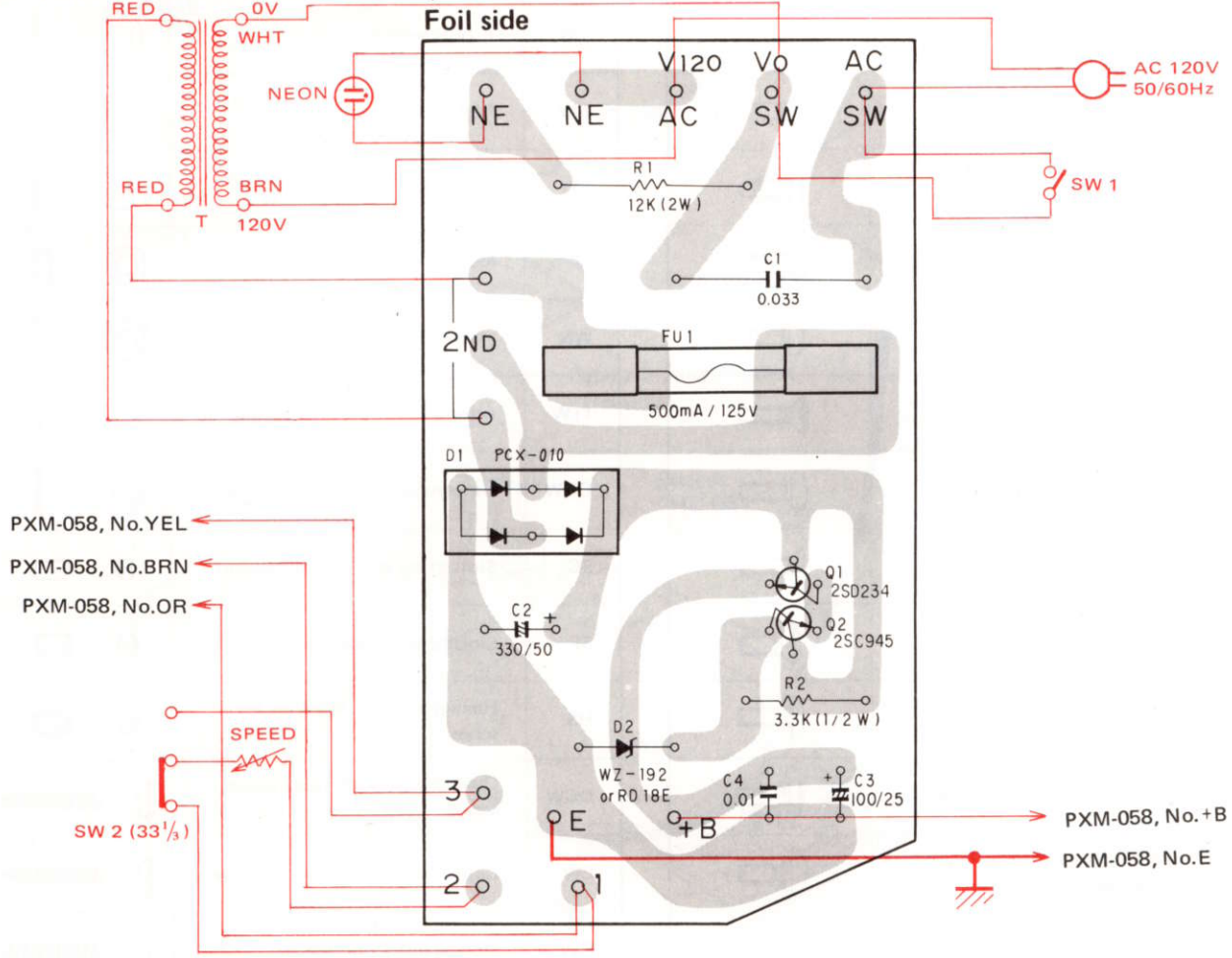

Parts List of Power Supply Assembly (PWR-032)

Symbol	Part No.	Description
C1	PCL-018	Ceramic 0.033 250V
C2	CEA 331P 50	Electrolytic 330 50V
C3	CEA 101P 25	Electrolytic 100 25V
C4	CKDYF 103Z 50	Ceramic 0.01 50V
R1	RS2P 123J	Metal oxide 12k 2W
R2	RD½PS 332J	Carbon film 3.3k ½W
Q1	2SD234	Transistor
Q2	2SC945P or K	Transistor
D1	PCX-010	Bridge rectifiers
D2	WZ-192 (RD18E)	Zener diode
	PNS-001	Heat sink
FU1	PEK-004 K91-006	Fuse (500mA) Fuse holder

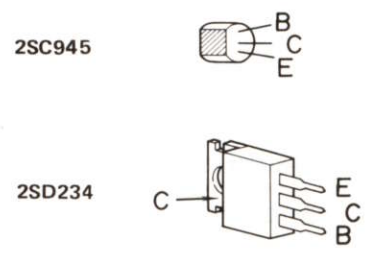

7.2 SCHEMATIC DIAGRAM

NOTICE: The component parts of this motor (PXM-058), shown in below schematic diagram,

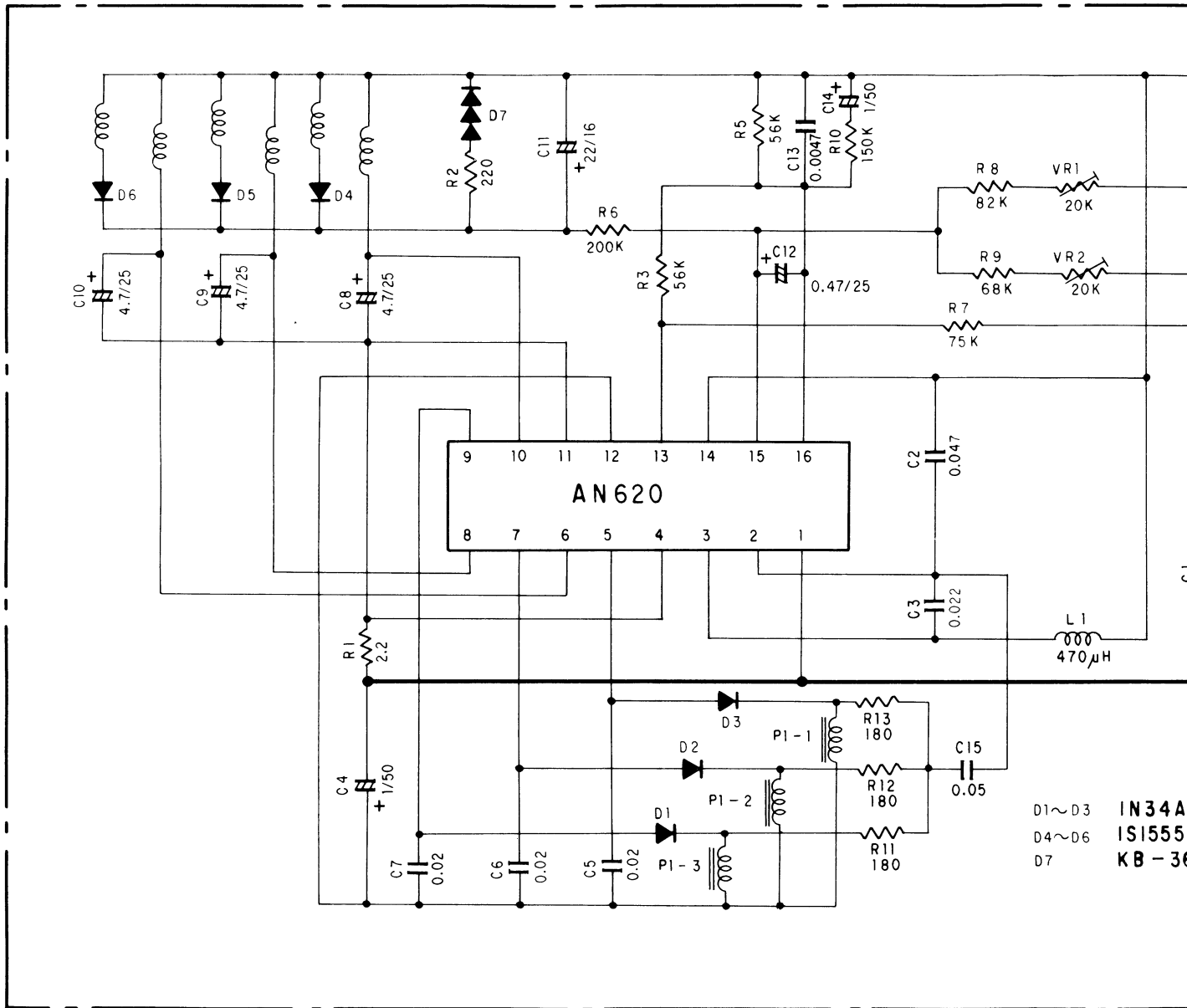

D1~D3 IN34A
 D4~D6 1S1555
 D7 KB-30

RESISTORS ;
 IN OHM 1/4W ±5% TOLERANCE UNLESS OTHERWISE NOTED k ; kΩ M ; MΩ

SWITCHES ;
 SW1 POWER ON/OFF
 SW2 SPEED SELECTOR

CAPACITOR ;
 IN μF UNLESS OTHERWISE NOTED p ; pF

low schematic diagram, can not be supplied.

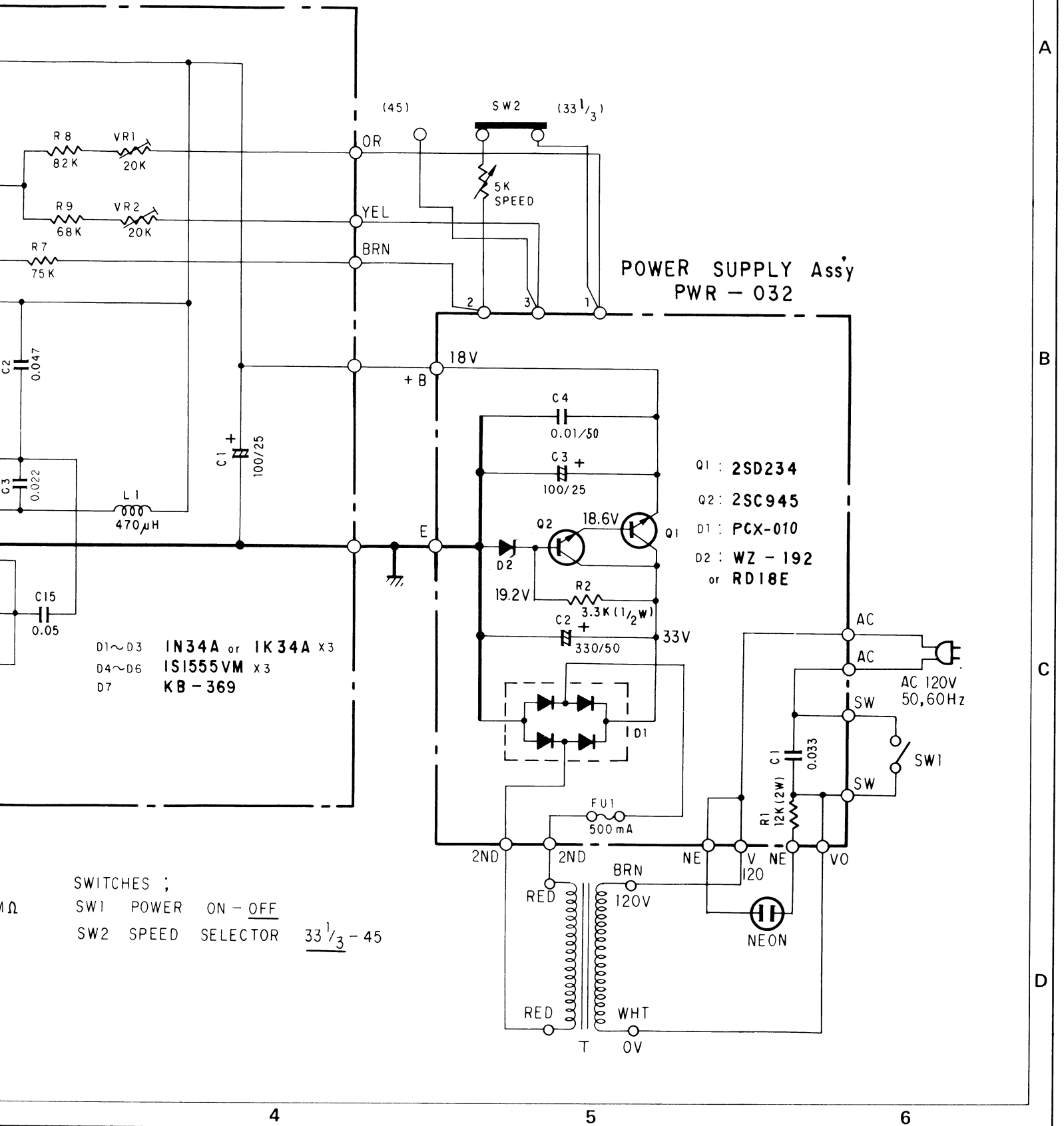

8. KUT type SCHEMATIC DIAGRAM, P.C. BOARD PATTERN

8.1 SCHEMATIC DIAGRAM

NOTICE: the component parts of this motor (PXM-058), shown in below schematic diagram,

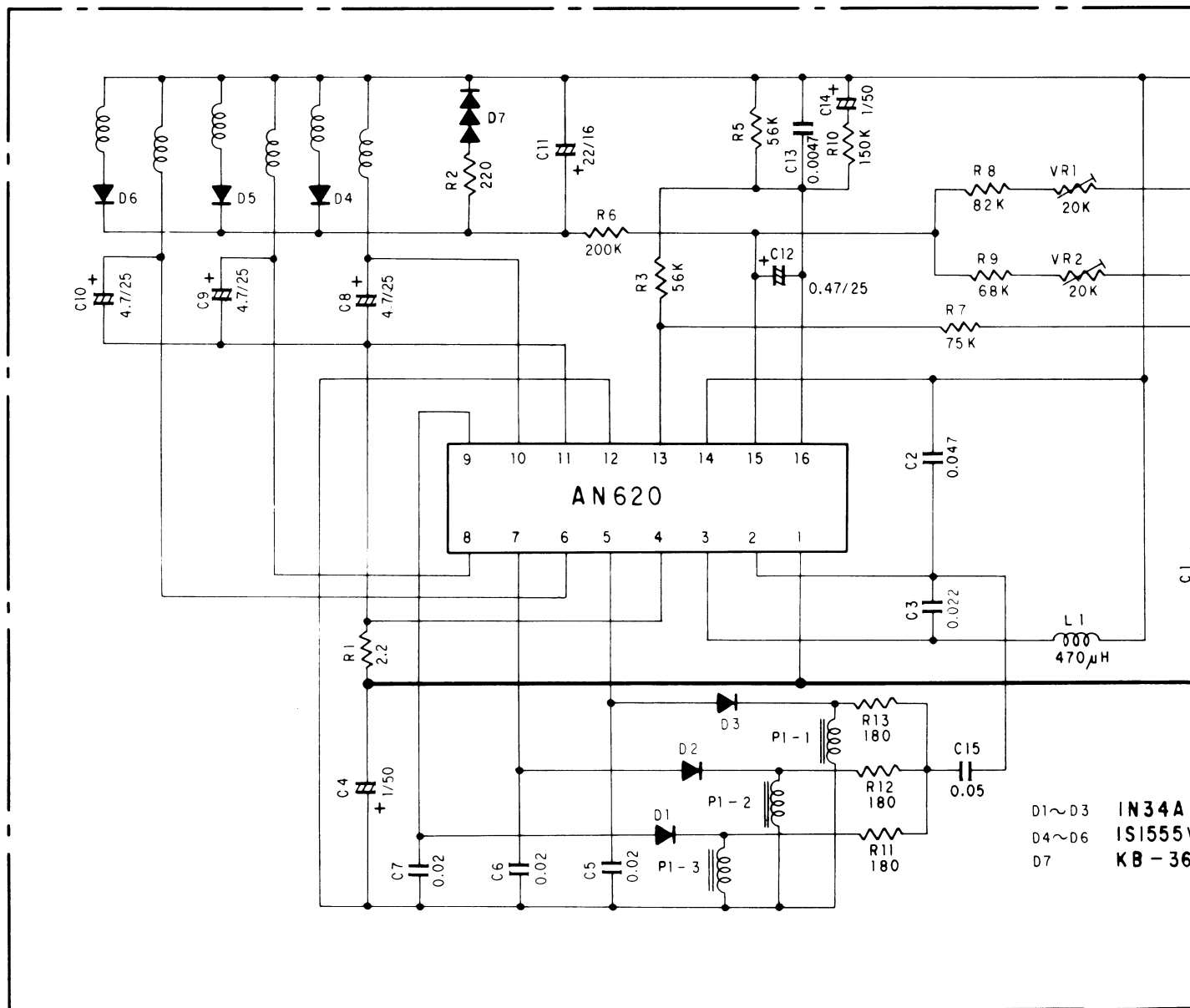

RESISTORS :

IN OHM 1/4W ±5% TOLERANCE UNLESS OTHERWISE NOTED k ; kΩ M ; MΩ

CAPACITOR :

IN μF UNLESS OTHERWISE NOTED p ; pF

SWITCHES ;

SW1 POWER ON

SW2 SPEED SEL

RD PATTERN AND PARTS LIST.

low schematic diagram, can not be supplied.

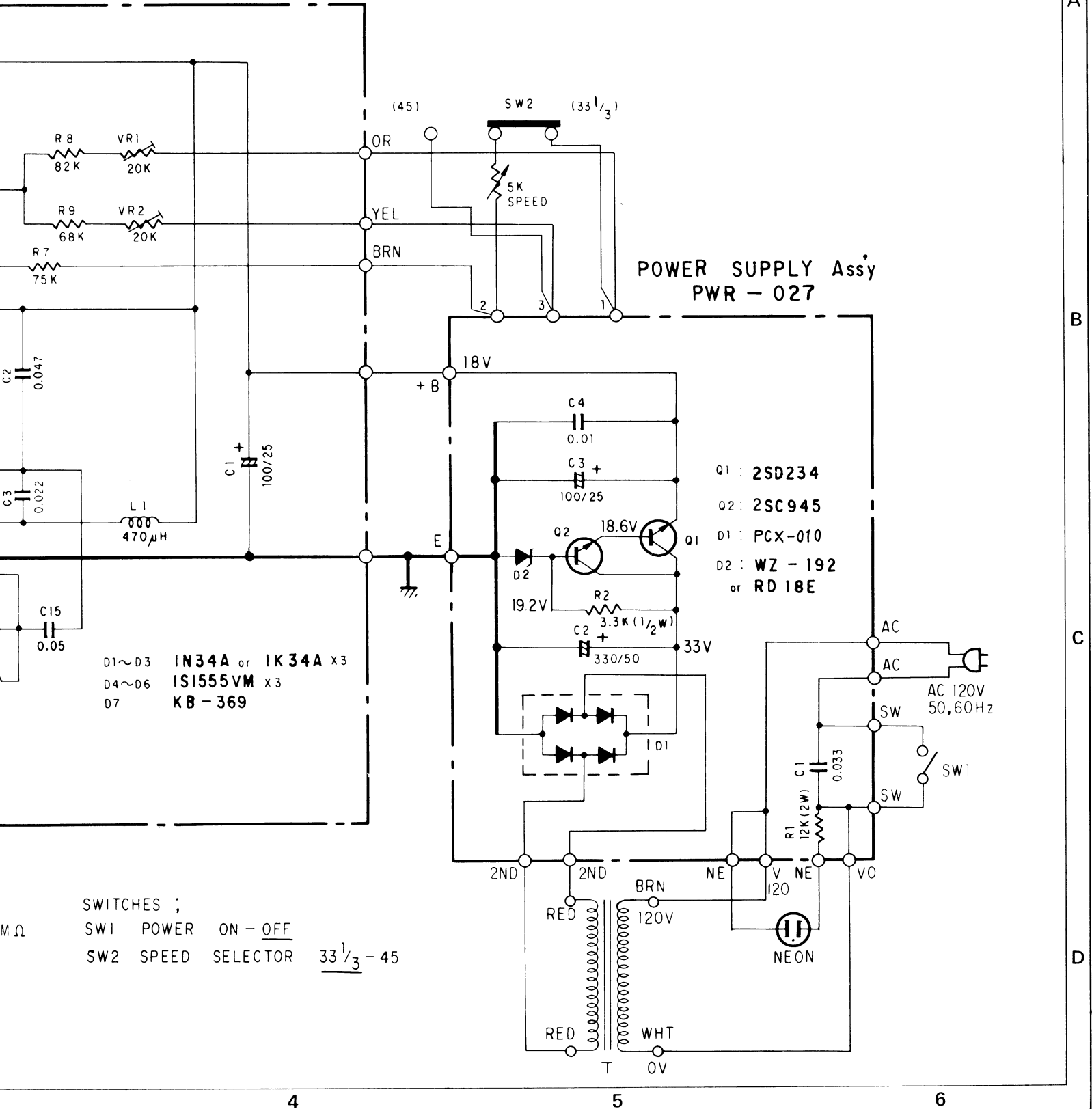

8.2 POWER SUPPLY ASSEMBLY (PWR-027)

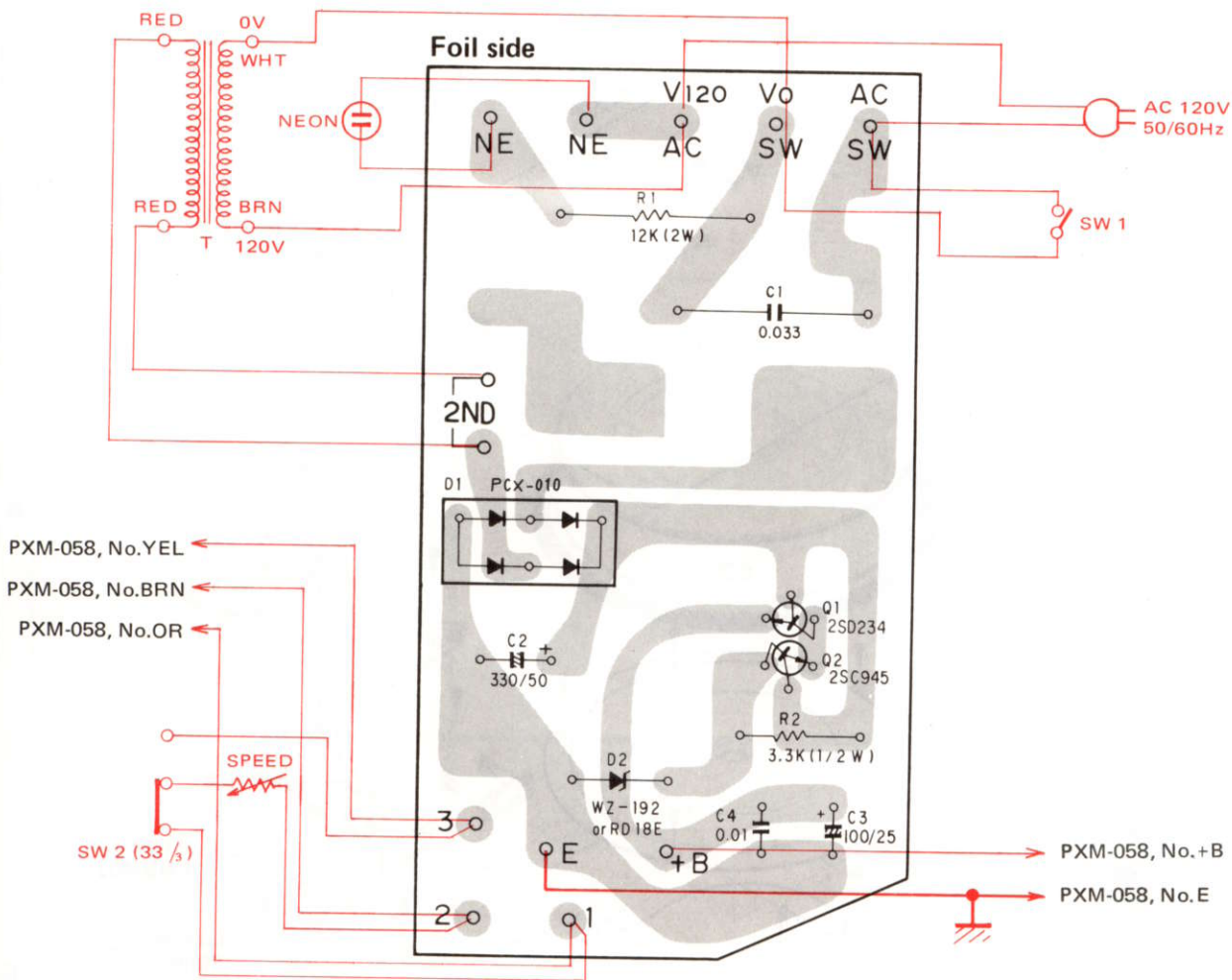

Parts List of Power Supply Assembly (PWR-027)

Symbol	Part No.	Description
C1	KCE-009	Ceramic 0.033 250V
C2	CEA 331P 50	Electrolytic 330 50V
C3	CEA 101P 25	Electrolytic 100 25V
C4	CKDYF 103Z 50	Ceramic 0.01 50V
R1	RS2P 123J	Metal oxide 12k 2W
R2	RD½PS 332J	Carbon film 3.3k ½W
Q1	2SD234	Transistor
Q2	2SC945P or K	Transistor
D1	PCX-010	Bridge rectifiers
D2	WZ-192 (RD18E)	Zener diode
	PNS-001	Heat sink

2SC945

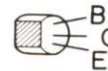

2SD234

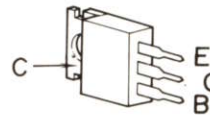

9. HGT type EXPLODED VIEWS

9.1 CABINET

The parts indicated the designation and parts number are newly-employed as HGT model.
The parts without description are the same as the parts in the KCT model.

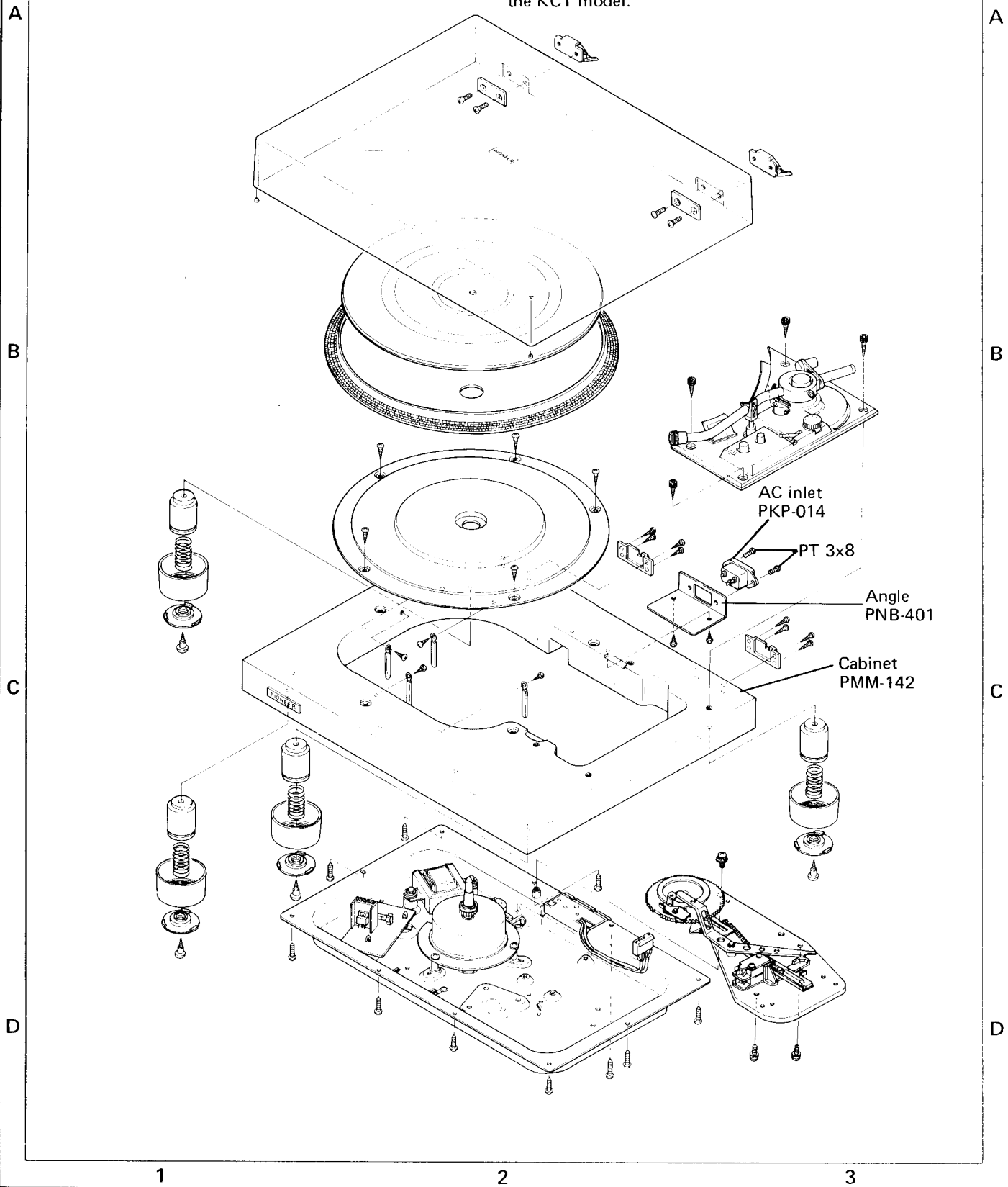

9.2 TONEARM

The parts indicated the designation and parts number are newly-employed as HGT model.
 The parts without description are the same as the parts in the KCT model.

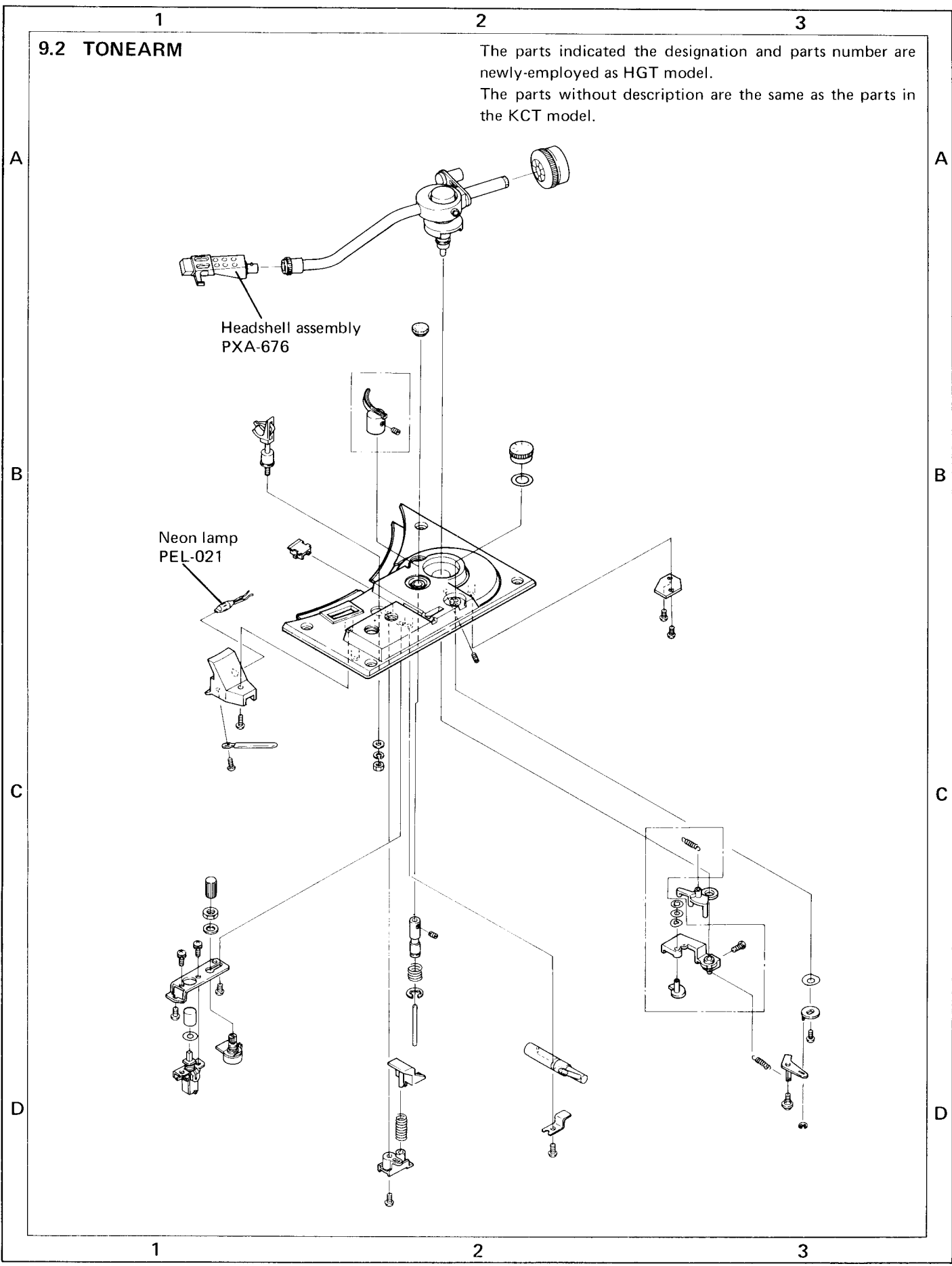

1 2 3

9.3 MECHANISM

The parts indicated the designation and parts number are newly-employed as HGT model.
The parts without description are the same as the parts in the KCT model.

A

A

B

B

C

C

D

D

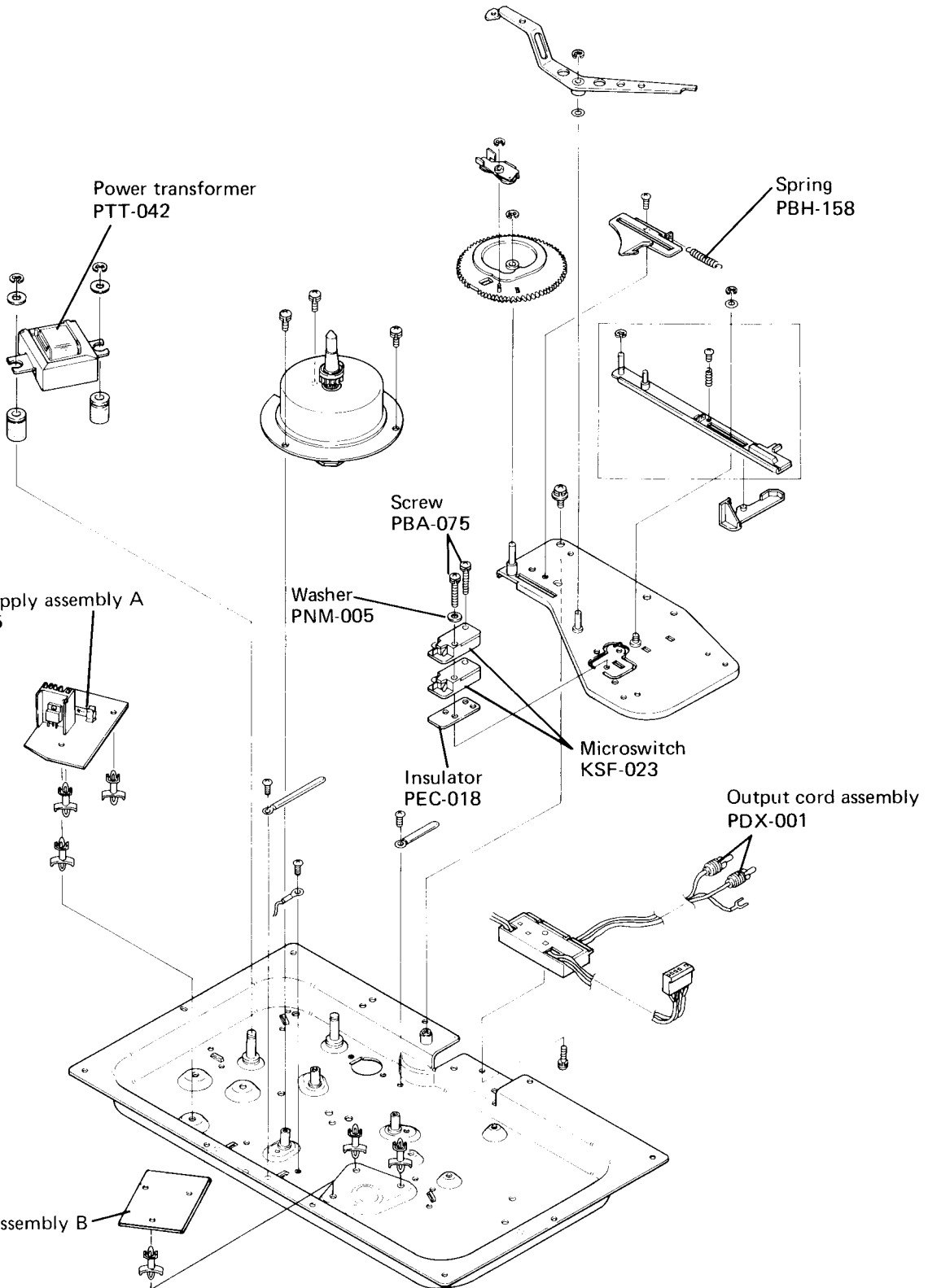

1

2

3

9.4 PACKING

The parts indicated the designation and parts number are newly-employed as HGT model.
The parts without description are the same as the parts in the KCT model.

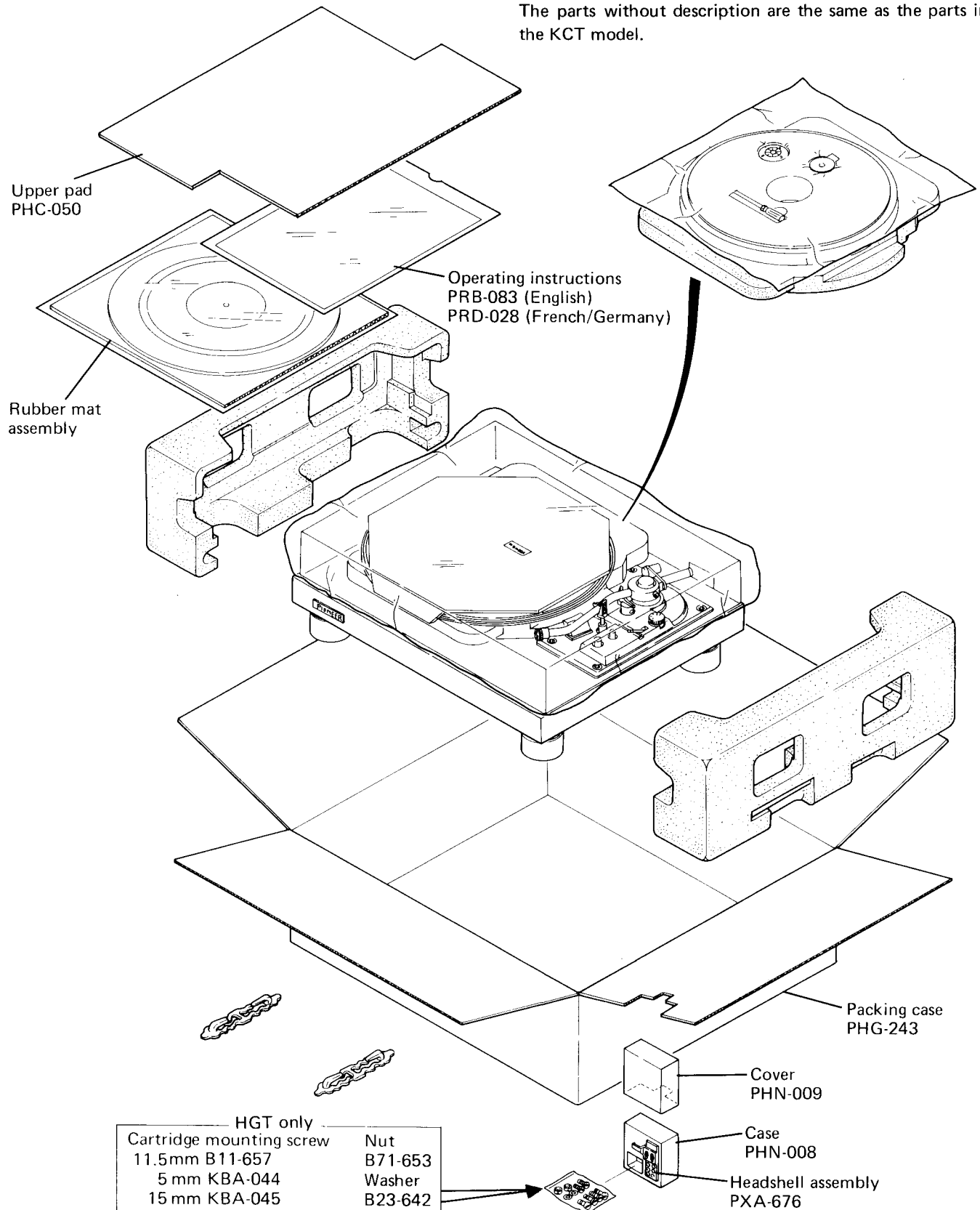

10. HGT type SCHEMATIC DIAGRAM, P.C. BOARD PATTERNS AND PARTS LIST.

10.1 POWER SUPPLY ASSEMBLY (PWR-035)

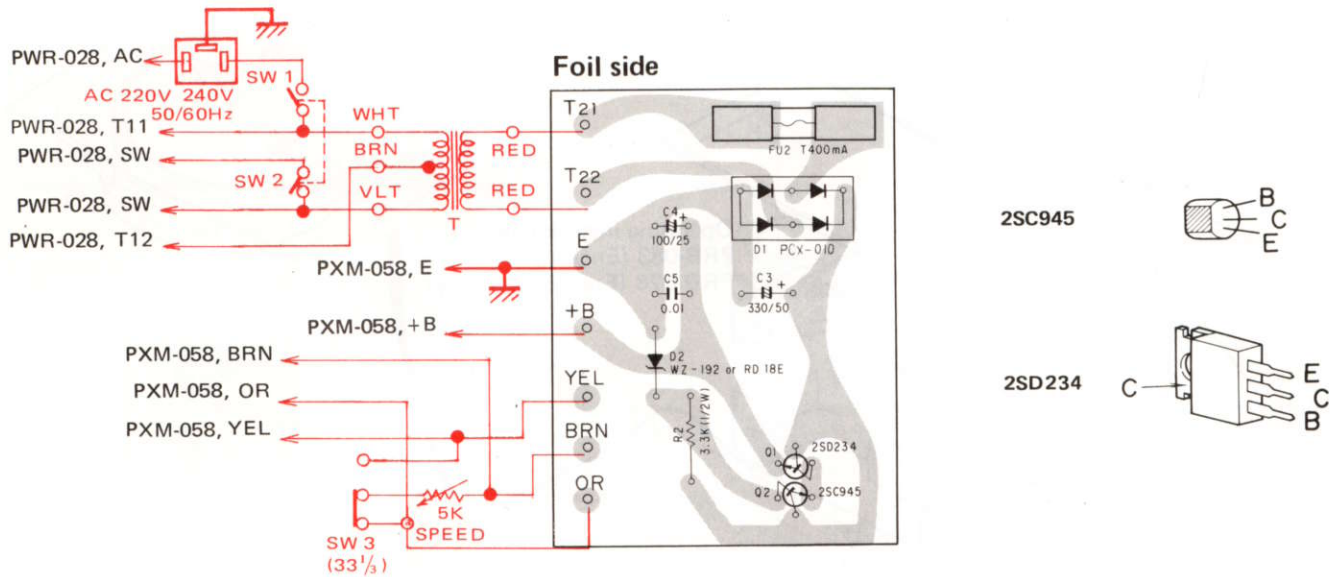

10.2 POWER SUPPLY ASSEMBLY B (PWR-028)

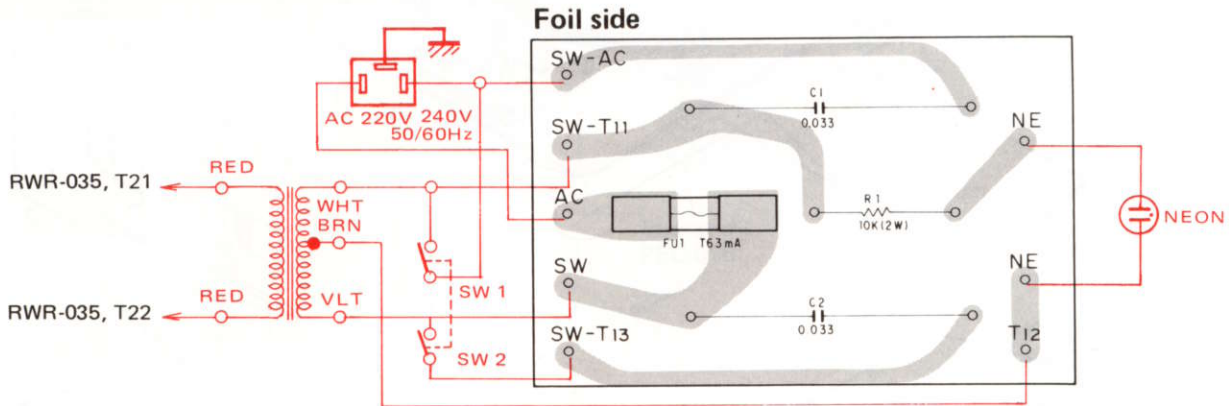

Parts List of Power Supply Assembly A (PWR-035)

Symbol	Part No.	Description		
C3	CEA 331P 50	Electrolytic	330	50V
C4	CEA 101P 25	Electrolytic	100	25V
C5	CKDYF 103K 50	Ceramic	0.01	50V
R2	RD 1/2 PS 332J	Carbon film	3.3k	1/2 W
Q1	2SD234	Transistor		
Q2	2SC945P or K	Transistor		
D1	PCX-010	Bridge rectifiers		
D2	WZ-192 (RD18E)	Zener diode		
	PNS-001	Heat sink		
FU2	PEK-005	Fuse (400mA)		
	KKR-001	Fuse holder		

Parts List of Power Supply Assembly B (PWR-028)

Symbol	Part No.	Description		
C1	PCL-023	Ceramic	0.033	250V
C2	PCL-023	Ceramic	0.033	250V
R1	RS2P 103J	Metal oxide	10k	2W
FU1	PEK-020	Fuse (63mA)		
	KKR-001	Fuse holder		

10.2 SCHEMATIC DIAGRAM

NOTICE: The component parts of this motor (PXM-058), shown in below schematic diagram,

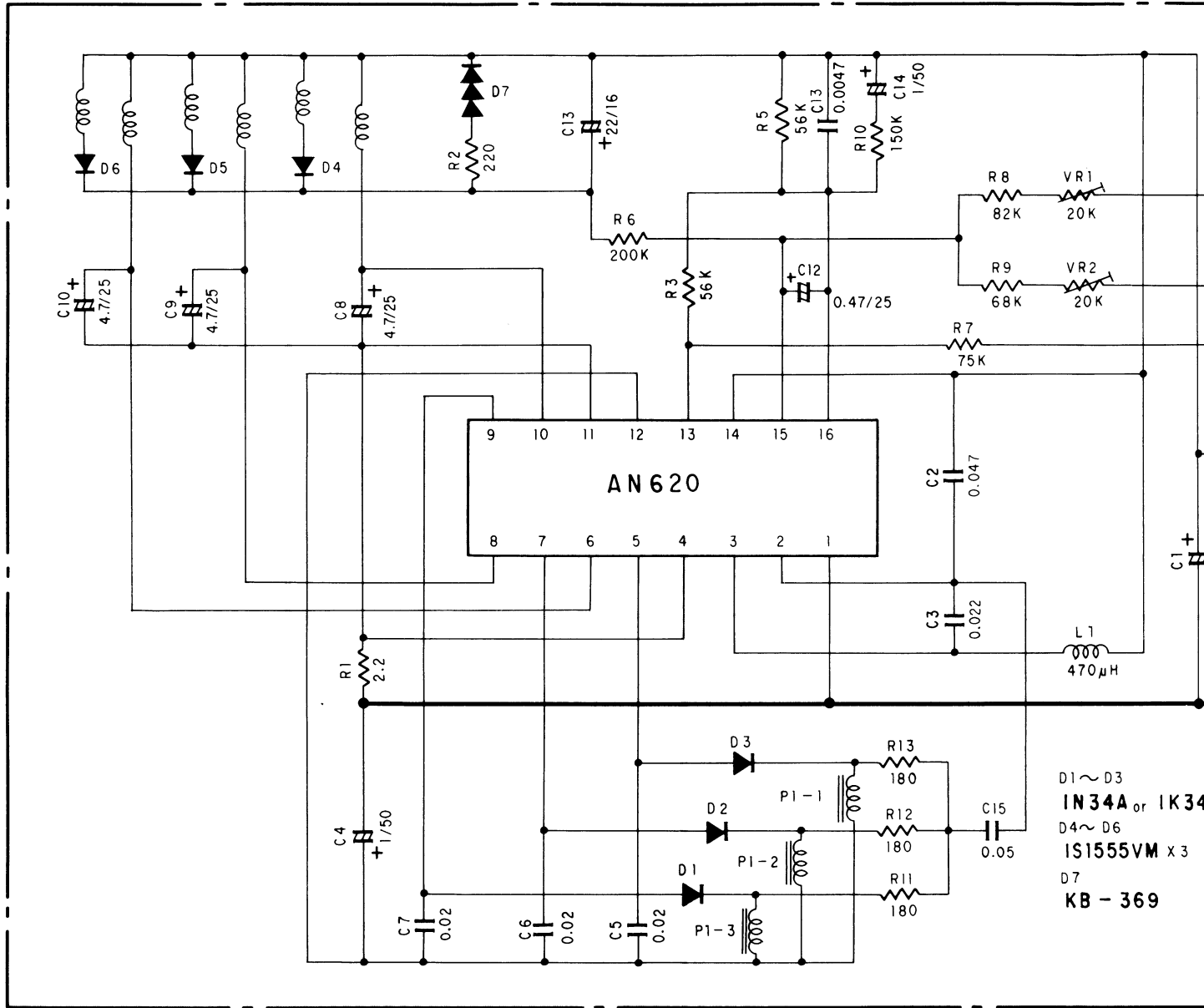

RESISTORS :

IN OHM 1/4W $\pm 5\%$ TOLERANCE UNLESS OTHERWISE NOTED k ; k Ω M ; M Ω

CAPACITORS :

IN μ F UNLESS OTHERWISE NOTED p ; pF

SW1 POWER ON -
 SW2 POWER ON -
 SW3 SPEED 33 1/2

